



Datos Técnicos

Luminaria fija de techo.

Corriente de entrada AC 230V 50-60Hz.

Lámpara 3x LED GU10 reposición Ø50 x h 50mm.

Potencia máxima recomendada 8W. (700lm)

Technical Data

Fixed ceiling luminaire.

Input current AC 230V 50- 60Hz.

Retrofit 3x LED lamp GU10 Ø50 x h 50mm.

Recommended maximum power 8W. (700lm)

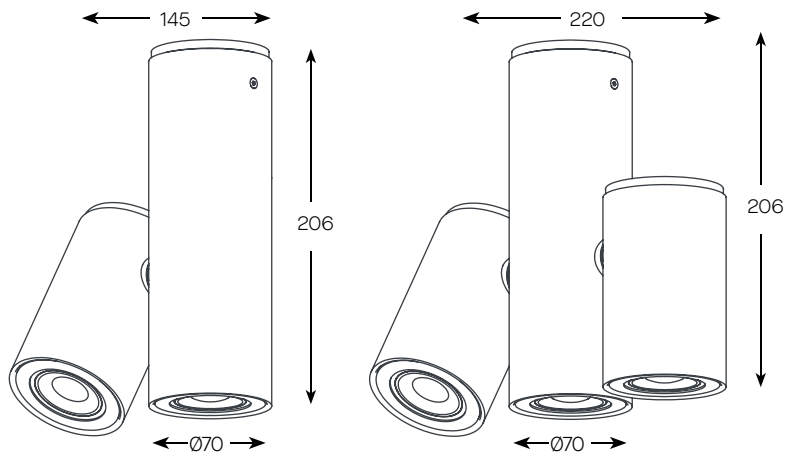

cod. 6236, 6237, 4327

cod. 6234, 6235, 4235

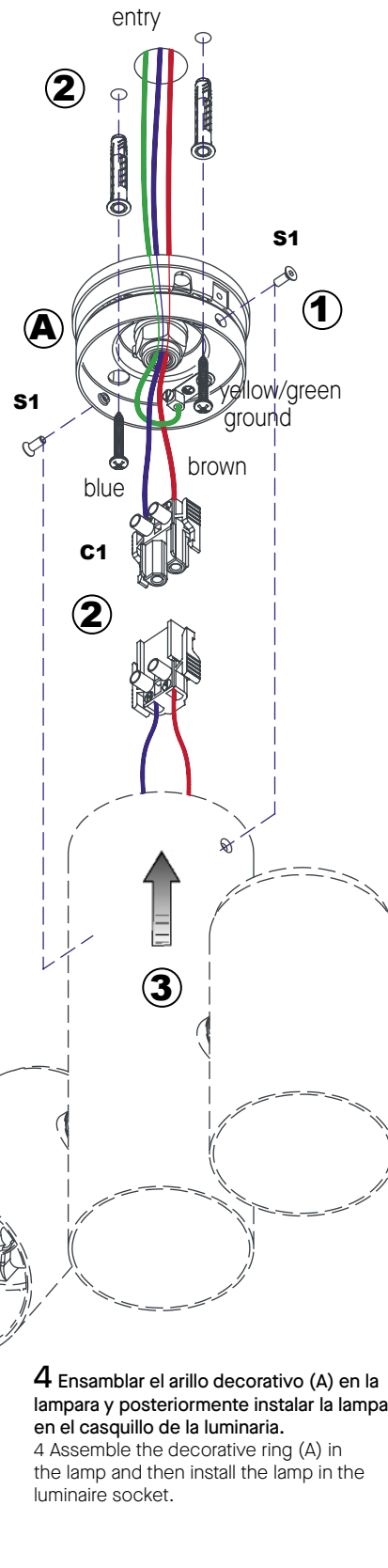

1 Liberar el soporte de fijación a techo, retirando los tornillos (S1).

1 Release the ceiling fixing bracket, removing the screws S1.

2 Realizar la fijación a techo del soporte (A), posteriormente separar la unión del conector (C1), para continuar realizando el conexionado a la instalación eléctrica.

2 Carry out the fixing to the ceiling of the support (A), then separate the connection from the connector (C1), to continue making the connection to the electrical installation.

3 Volver a ensamblar la dos partes de la luminaria, uniendo el conector (C1) y posteriormente utilizar tornillos (S1) para completar el ensamblado.

3 Reassemble the two parts of the luminaire, joining the connector (C1) and then use screws (S1) to complete the assembly.

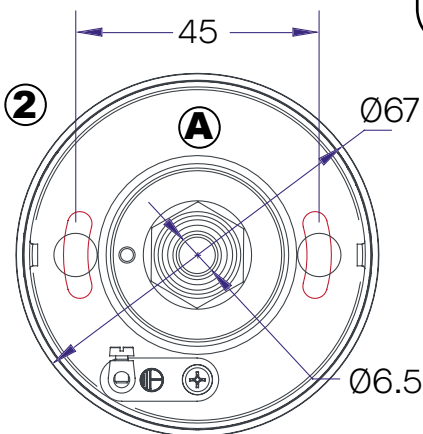
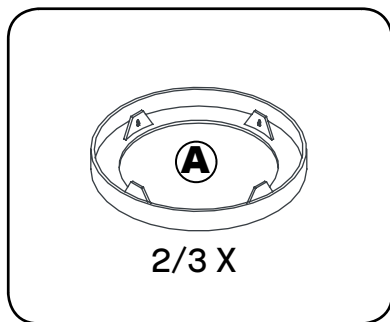

Only led bulbs

4 Ensamblar el arillo decorativo (A) en la lámpara y posteriormente instalar la lámpara en el casquillo de la luminaria.

4 Assemble the decorative ring (A) in the lamp and then install the lamp in the luminaire socket.